

**GOLDEN
SENSE**

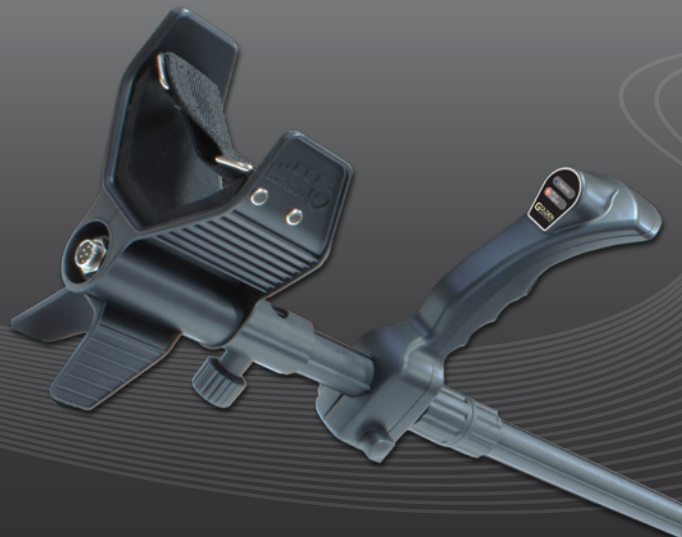

www.noktadetectors.com

USER MANUAL

Thank you for choosing and purchasing our Nokta GOLDEN SENSE detector.

Manufacturing high-tech metal detectors since 2001, Nokta Detectors has played a key role in the development of this sector. Nokta Detectors is particularly known for its technological know-how and professional staff.

Seeking to create different kind of technology, Nokta Detectors offers both high-quality products and services to its consumers all around the world. Nokta Detectors has been operating under the principle that environmental and community responsibility, customer satisfaction and insistence on high-quality are of the utmost importance.

Nokta Detectors aims to remain a leading pioneer in its sector, winning the trust of its consumers and always being the preferred choice for metal detecting.



WARNINGS	3-4
ASSEMBLY	5-8
CORRECT WAY OF HOLDING	9
CORRECT WAY OF SWEEPING	10
BATTERY	11-12
DEVICE INTRODUCTION	13-14
PRINCIPLES OF SEARCHING	15
TURNING ON THE DEVICE AND SETTINGS	16-18
SENSITIVITY SETTING	17
GROUND BALANCE	18
SEARCHING AND METAL DETECTION	19-21
SEARCH MODES	20-21
TECHNICAL SPECIFICATIONS	22

WARNINGS!**LEGAL WARNINGS**

▶ When using the device, comply with all applicable laws and regulations. Do not use the device in private premises, historic sites and military zones. Notify the authorities of any historical or cultural findings.

WARNINGS ABOUT THE DEVICE

- ▶ This is a high-tech electronic device. Do not assemble or use the device before reading the user manual.

- ▶ Do not expose the device or the search coil to very hot or cold conditions for extended periods of time. (Storage Temperature: 0°C (32°F) - 40°C (104°F))

- ▶ Do not immerse the device or its accessories (except the search coil) in water; do not expose them to extreme humid conditions.

- ▶ Protect the device from external impact, especially during transportation.

- ▶ The device can only be opened and repaired by authorized service technicians. The warranty will be voided if the device is opened by you or an unauthorized person.

IMPORTANT

Do not use the device indoors. The device will constantly give target signals inside places like homes where there are many metals present. Use the device outdoors, in open fields.

Do not let another detector or an electromagnetic device come in close proximity (10m (33ft.)) to the device.



IMPORTANT

Do not carry any metal objects while using the device. Keep the device away from your shoes while walking. The device may detect the metals on you or inside your shoes as targets.



For Consumers within the European Union: Do not dispose of this equipment in general household waste. The crossed wheeled bin symbol on this equipment indicates this unit should not be disposed of in general household waste, but recycled in compliance with local government regulations and environmental requirements.



FCC STATEMENT

This device complies with Part 15 of the FCC Rules. Operation is subject to the following two conditions: (1) this device may not cause harmful interference, and (2) this device must accept any interference received, including interference that may cause undesired operation.



- 1) System Box
- 2) Handle
- 3) Search Coil
- 4) Search Coil Cover
- 5) Extension Shaft
- 6) System Box Case
- 7) Battery Case
- 8) 8 AA Batteries
- 9) System Connection Cable
- 10) Wingnut
- 11) Fastening Screw
- 12) Washers
- 13) Headphones



Coil cover use is optional. It protects the search coil from scratches. If you want to use the cover, remove the protective sheets from the tapes inside the cover, attach the cover to the coil and press firmly to make them stick together. Once the cover is attached, you cannot take it off.

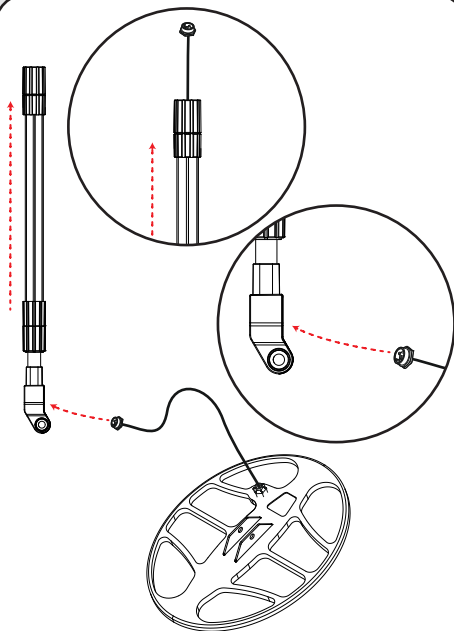

Insert the coil cable into the shaft. Do not extend the shaft prior to this step! Pull the cable out from the other end of the shaft.

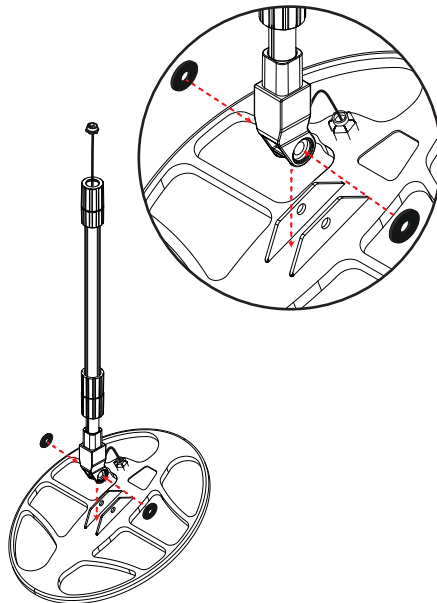

Place the washers into the openings on both sides at the end of the extension shaft.

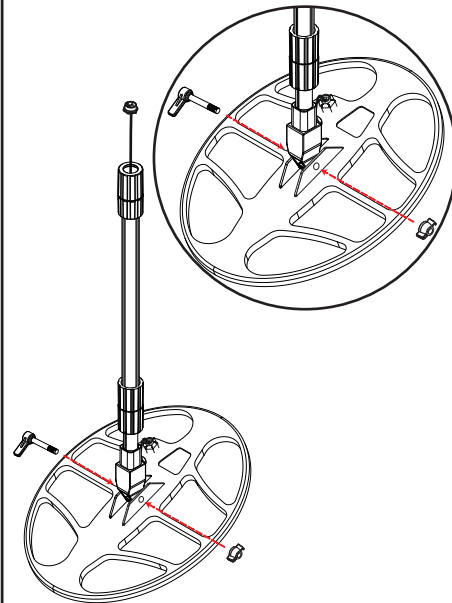

After placing the shaft on the coil as shown in the picture, insert the fastening screw through the hole and tighten it using the wingnut.

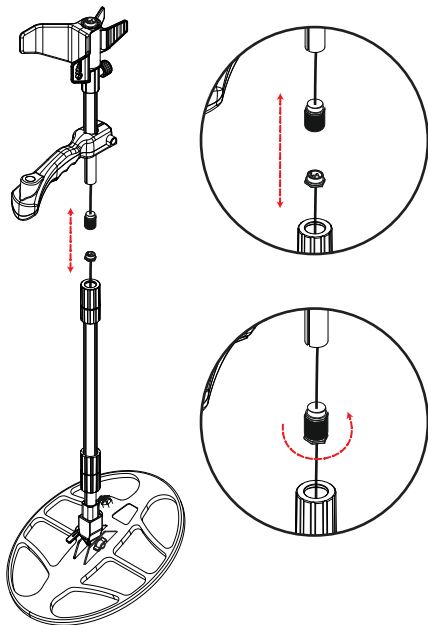

Connect the end connector on the search coil cable with the connector underneath the handle and tighten.

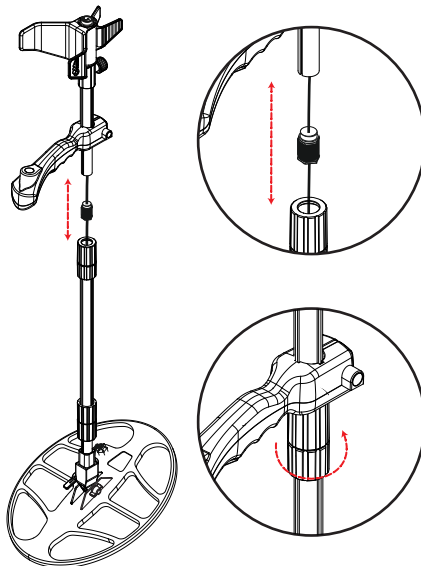

Insert the shaft in its socket underneath the handle and start rotating the twist lock. As you rotate the twist lock it will slide down. Before rotating the twist lock all the way, push the shaft up again making sure that it is in place and secure it by tightening the twist lock.

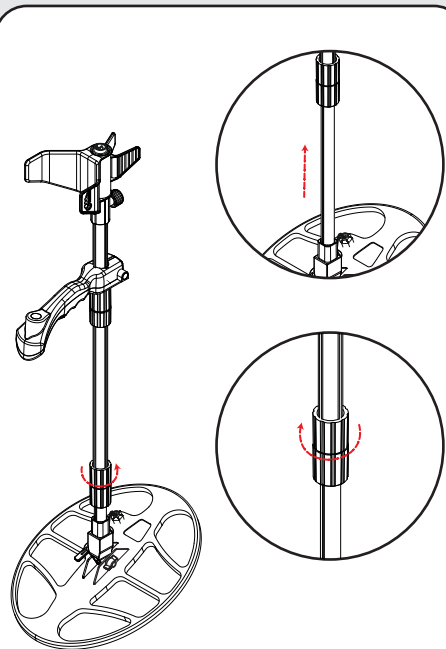

To adjust the height of the device, loosen the twist lock on the shaft. After adjusting the shaft length to your height, re-tighten.

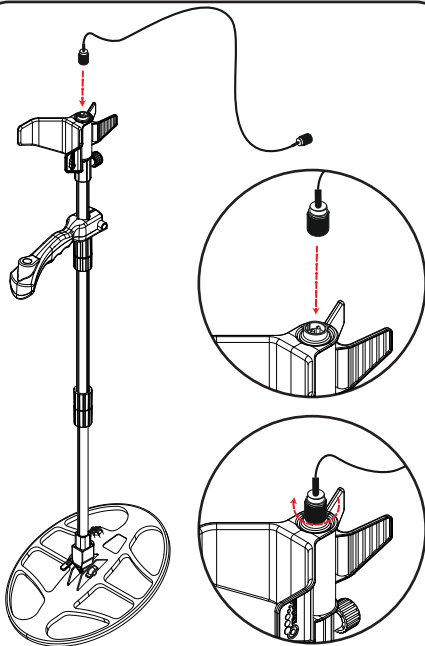

Insert the end connector on either end of the system connection cable into the socket on the handle and tighten securely.

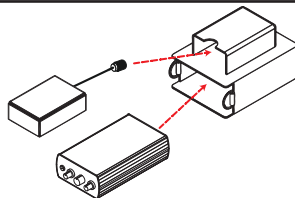

Place the system box and the battery in their proper compartments of the system box case.

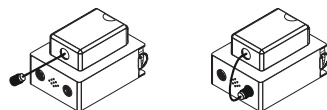

Insert the battery cable through the hole on the case, plug it into the battery input socket underneath the system box and tighten securely.

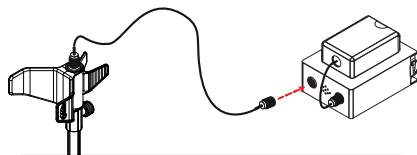

Plug the other end of the system connection cable into the coil input socket underneath the system box and tighten securely.



You may hang the system box around your neck using the neck strap or attach it to your belt as shown in the pictures.

CORRECT WAY OF HOLDING



Shaft height is wrong.

It is very important to adjust the shaft to your height correctly to be able to search without discomfort and fatigue.



Shaft height is correct.

Adjust the height of the shaft so that you are standing in an upright position, your arm is relaxed and the search coil is approximately 5cm (~2") above the ground.

X



Wrong search coil angle.

X



Wrong search coil angle.

✓



Correct search coil angle.

Incorrect way of sweeping.

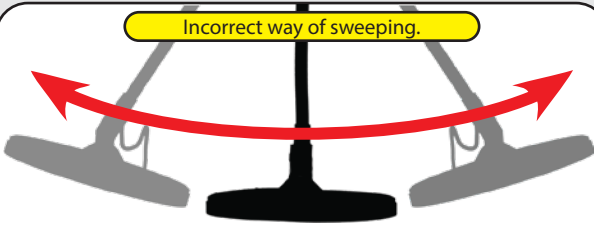

It is important to keep the search coil parallel to the ground in order to get accurate results.

Correct way of sweeping.

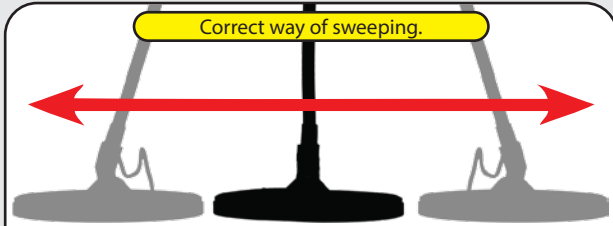

The search coil must be parallel to the ground at all times.

BATTERY



The device comes with 8 AA Alkaline batteries and a battery case. Insert the batteries in the case paying attention to the + (plus) and - (minus) poles. When batteries are full, they will provide approximately 25-30 hours of use. Different types or brand of batteries may have different lifetimes.

LOW BATTERY: When the batteries are low, the device will produce a warning sound approximately once every minute. The device will shut down automatically 3-4 hours after the warning.



Optional

Optional

Those who prefer rechargeable batteries can purchase the optional lithium polymer battery and search over 50 hours.

You may also purchase the optional car charger with the lithium polymer battery and charge your battery on-the-go as well.



Optional

1



2



3



4



5



6



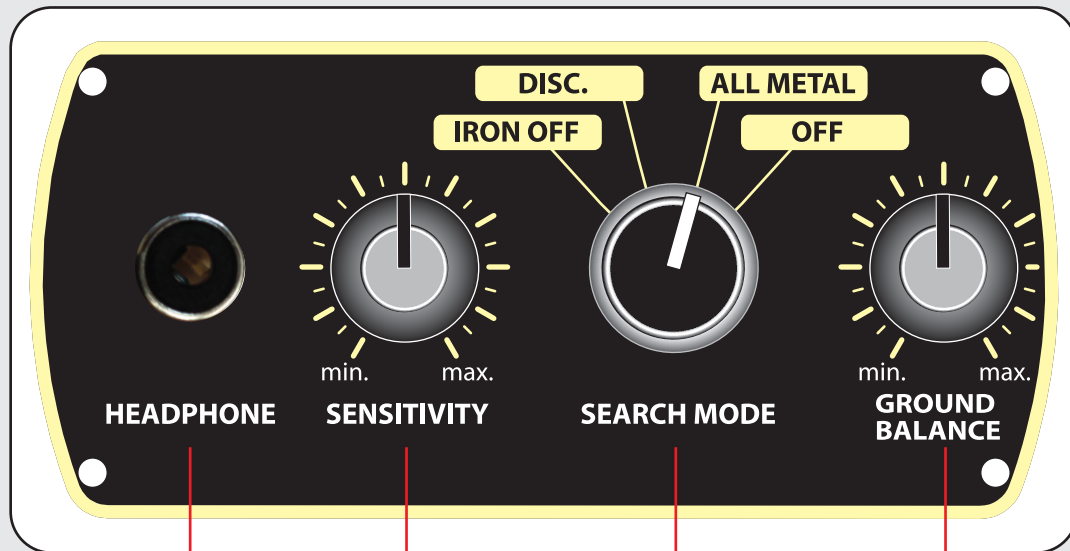

Headphone Input:
To better hear the sounds produced by the device, connect the headphones to the system box.

Sensitivity Setting:
Is the depth setting of the device. For details please see page 17.

Search Mode Knob:
Is used to select the search mode as well as turning on/off the device.

Ground Balance Knob:
Is used to eliminate ground noise. For details please see page 18.

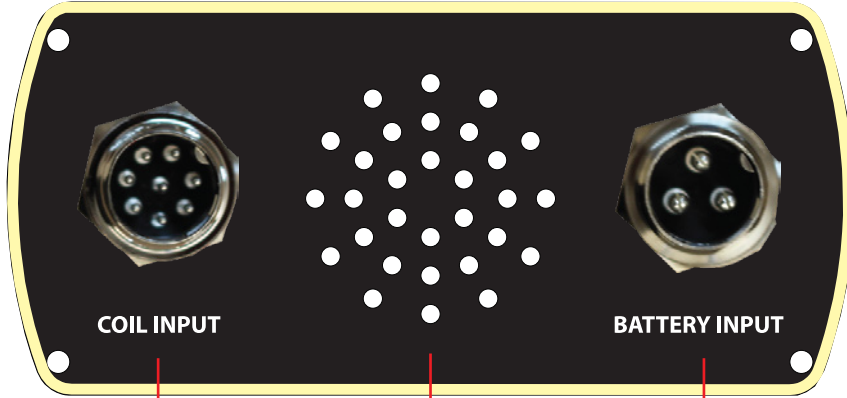

COIL INPUT

BATTERY INPUT

Search Coil Input Socket:
Is the connection point of the coil to the system box.

Speaker:
Emits sounds produced by the device.

Battery Input Socket:
Is the connection point of the battery to the system box.



Discrimination Indicator: Shows the type of metal detected. For details about discrimination please see page 20.

It is important to pay attention to the following points before and during search in terms of device performance and getting accurate results:

- 1- The device operates on the principle of motion. This means that you must move the search coil over the target or the target over the search coil, in order for the device to see it. In other words, metal detection is not possible without moving the search coil.
- 2- Based on the same principle, do not hold your search coil still over a detected target. If the coil is held still over the target, the device cancels out the process and does not see the target anymore. When you start moving the coil again, the device will resume detection.
- 3- For correct metal detection, the way you hold the shaft and sweep the search coil and keeping the coil parallel to the ground are very important factors. Before starting to search, please refer to the related sections in the manual. (pages 9-10)

1 TURNING ON THE DEVICE



Rotate the sensitivity knob to maximum and the ground balance knob to the mid-level.



To turn on the device, rotate the search mode knob to the desired mode. Turn the same knob to OFF position to when you want to turn off the device.



When the device is turned on, a melody will be heard and both LEDs on the handle will light up. Approximately 20 seconds later, the LEDs on the handle will go off and you will hear a tone indicating that the device is ready to use.

2 SENSITIVITY SETTING

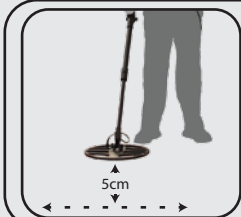

Holding the search coil 5cm. above the ground, sweep it right and left.



If the detector emits false signals due to interference, reduce the sensitivity until the signals go away and start searching.

Sensitivity setting is used to eliminate interferences caused by electromagnetic waves in the surrounding environment. Electromagnetic waves may result from power lines in the surrounding environment or from the operation of electrical devices, radars, wireless radios, and even TVs.

Sensitivity is also the depth setting for the device. Therefore, it is recommended that you do not lower it too much suddenly but gradually decrease it to determine the level where you are not getting any interference and continue searching.

GROUND BALANCE

Especially in mineralized grounds (containing chemicals, salts and minerals), target signal is negatively affected by the "noise" caused by ground mineralization. This situation may prevent the detector from getting a clean signal from the target necessary for metal detection and accurate discrimination. Ground balancing is a process through which the metal detector is able to cancel out the negative effects caused by ground mineralization.



Golden Sense ground balance setting consists of 3 different levels:

1) MID-LEVEL: Offers the most ideal and stable detection capability on different types of grounds without sacrificing depth.

2) LEFT AREA: Recommended for more precise detections and for experienced users. The device may generate false signals in changing ground conditions, even over holes dug for testing. Therefore, if you set the ground balance in this area, you have to take this factor into consideration.

3) RIGHT AREA: Is used to eliminate high mineralized rocks and soils. If you are on a highly mineralized ground and the device is still getting ground noise with the ground balance set at mid-level, turn the ground balance knob to the right in very small increments to eliminate the noise.

The most important thing to pay attention here is that as the ground balance goes into the right area, the device will start losing depth for some non-ferrous metals except for gold. When the ground balance setting reaches the maximum point the device will detect iron and gold but it will not detect some non-ferrous metals.

IMPORTANT!: If you are searching on high mineralized ground (extremely salty soil, wet beach sand, wet plowed land or highly magnetic ground conditions) you may not be able to ground balance the device. In such a case, leave the ground balance knob at around level 6-7 and turn the SEARCH MODE knob to IRON OFF. This will eliminate the noise and false signals caused by mineralization.

3 SEARCHING AND METAL DETECTION



After the ground balance and sensitivity settings are adjusted, you can start searching by lifting the search coil 5cm. above the ground and sweeping it right and left, keeping it parallel to the ground.

NOTE: You may have to re-adjust the sensitivity and ground balance settings while searching because as you change your location there may be changes in the ground or surrounding electromagnetic interferences as well. Therefore, you may need to repeat the above processes should your device starts receiving interference or noise.

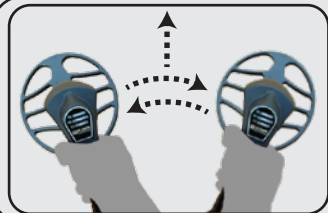

To avoid missing smaller and deeper targets, sweep the search coil both from right to left and left to right over each area you are scanning, slightly overlapping the sweeps as you move forward.



When the device detects a metal, it will produce an audible tone. If the device is in discrimination mode, the LEDs on the handle will light up at the same time.

PINPOINTING

For pinpointing the exact location of the target, move the search coil over the target with short and faster/slower sweeps.

SEARCH MODES

**All Metal:**

This is the deepest mode of the device. The device will not discriminate metals in this mode. It will produce one warning tone for all metals and the LEDs on the metal discrimination indicator will not light up.

**Discrimination:**

In this mode, the device will produce different tones based on metal type. At the same time, the LEDs on the handle will also light up based on metal type. Depths in this mode may vary compared to All Metal mode.

The device has 2 tone audio discrimination and it has 2 different color LEDs for visual discrimination. The device produces a different tone for Ferrous and for Gold/Non-Ferrous metals. The low-tone is for ferrous metals. For gold/non-ferrous metals, the device produces a higher tone.

The LEDs on the handle will light up according to the detected metal's being Gold/Non-Ferrous or Ferrous. Both LEDs may light up in turn in case of Steel/Alloy detection and the device may produce a double-tone sound.

NOTE: Discrimination, just like in any other metal detector, may not always be 100% accurate. There are many different factors affecting discrimination accuracy. All metals based on their conductivity, alloy composition, shape, orientation underground, depth and ground mineralization are sensed differently by a detector.

Oxidized metals buried under ground for a long time such as tinplates and tins may produce gold like signals. Following the experienced metal detector users' rule of thumb "when in doubt, dig" is the right thing to do.

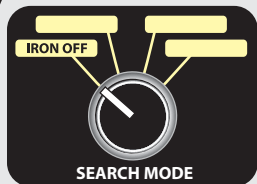

Iron OFF:

You can use this mode if you want to eliminate iron and similar ferrous metals while searching. When the device detects a ferrous metal in this mode, it will not produce a warning tone and the ferrous LED on the handle will not light up.

NOTE: Many metals considered to be trash may not produce a ferrous metal signal due to their alloy composition. For example, pull tabs may be sensed as a non-ferrous metal by most detectors because their signal is very similar to that of gold.

Operating Principle: Induction Balance

Operating Frequency: 17.5 KHz

Search Modes: 3 (All Metal/Discrimination/Iron Off)

Metal Identification: LED and audio warning

Audio Discrimination: 2 tones

Visual Discrimination: 2 LEDs (Ferrous & Gold/Non-ferrous)

Sensitivity Setting: Manual

Ground Balance: Manual

Search Coil: 34x41 cm (13"x16") waterproof Double-D

Battery: 8 x AA Alkaline Batteries

Headphone Output: 6.5mm mono

Length: 95-130cm (37"-51") extendable

Weight: 1.7kg (3.7lbs) including the search coil

Warranty: 2 years



Emek Mah. Sivatyolu Cad. Sakiz Sok. No: 4
34785 Sancaktepe - Istanbul / Turkey
Phone : +90 216 415 56 86
Fax : +90 216 415 63 43
E-mail: info@noktadetectors.com

